



Blueprint quad-tri B-double specifications (for trailers with turntable steering systems¹)

This document provides specifications for a quad axle B-double combination that is deemed to satisfy the Level 2 Performance Based Standards requirements set out in the ATC-approved national policy on quad axle groups (ATC 06/76(N)). Vehicles meeting this specification must also satisfy the conditions specified in the policy document.

Unless otherwise specified in the conditions below, the vehicle combination must have the dimensions shown in Figure 1 (± 10 mm), and is limited to the axle loads shown in Figure 1.

Figure 1: Baseline quad-tri B-double dimensions and loads

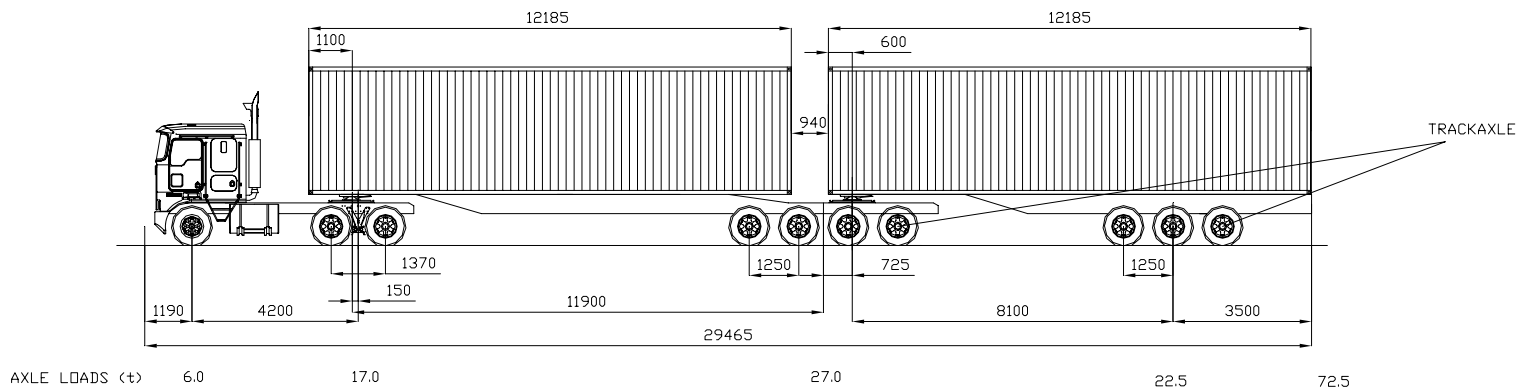

Loading

- Loading type is containerised freight.
- Load may be mixed or constant density. If mixed density, heavy freight must be loaded on the bottom and light freight on top.
- Under an agreed Australian Transport Council reform, a steer axle load of 6.5 t is allowed for heavy vehicles featuring the latest safety equipment and Euro 4 engine technology.

Brakes

One of the following conditions must be satisfied:

- full brake compatibility and load proportioning on all axles and all vehicle units; or
- an acceptable form of ABS/EBS and automatic slack adjusters on all vehicle units; or
- an acceptable form of ABS/EBS and automatic slack adjusters on a prime mover and full brake compatibility and load proportioning on all trailer axles.

Tyres

- The trailer must have either 22.5" or 19.5" rims, and tyres with a nominal section width between 265 mm and 295 mm, at the manufacturer's recommended inflation pressures.
- The prime mover must use either 11R22.5 or 295/80R22.5 tyres, at the manufacturer's recommended inflation pressures.

Trailers

- All trailer length dimensions must be as specified in Figure 1 (± 10 mm).
- The trailer width must not exceed 2.5 m.
- Trailers must be fitted with suspensions having a total roll stiffness not less than 17,800 Nm/deg per axle.
- Tare mass of the first trailer must be not less than 5.7 t (excluding container).
- Tare mass of the second trailer must be not less than 4.9 t (excluding container).
- Twist lock height must not exceed the following limits:

Container height	Twist lock height
8'6" (2.6 m)	1.40 m
9'6" (2.9 m)	1.26 m
10'6" (3.2 m)	1.10 m (not currently feasible)

Prime Mover

- Prime mover front overhang must be not more than 1.7 m.
- Prime mover width must not be more than 2.5 m.
- Prime mover wheelbase must be not more than 5.0 m and not less than 3.9 m.
- Equal share power divider must be fitted to distribute tractive force equally between the two drive axles.
- One of the following gearboxes and final drive ratio combinations must be fitted:

Gearbox	Minimum final drive ratio	Maximum final drive ratio
Eaton RTL 0918B	3.42	4.56
Mercedes Benz G330	4.10	4.56
SCANIA GRS905	3.07	4.56
Volvo AT2512C	3.42	4.56

- The drive group must have air suspension with a total roll stiffness of not less than 22,300 Nm/deg per axle.
- Peak engine power must be not less than 335 kW (455 hp).
- Peak engine torque must be not less than 1,422 Nm.
- Clutch engagement torque must be not less than 1,155 Nm.

Other requirements

- 'Long Vehicle' signs must be fitted.
- A side under-run protection system must be fitted to the first trailer.
- Other requirements set out in the ATC-approved national policy on quad axle groups (ATC 06/76(N)).

Note:

¹ the blueprint was designed using a Trackaxle steering system to demonstrate the potential of new technology to improve road access (from Level 3 to Level 2).